



WARNING: STM-S Stanchion Mount Double must be installed and grounded in accordance with the National Electrical Code (NEC) and local codes. Failure to do so will void the warranty and may result in serious injury and or damage to the luminaire Stanchion Mount.

NOTE: Always use UL Listed wire connectors for connections (by others).

NOTE: Save these instructions for future reference.

LUMINAIRE STANCHION MOUNT IS UL RECOGNIZED FOR ABOVE GRADE INSTALLATION ONLY

J-BOLT ANCHOR INSTALLATION

1. Install J-bolt anchor assembly over electrical conduit stub outs (by others) and into concrete pour form (form by others). The electrical conduit stub outs must pass through the center of the template bracket of the J-bolt assembly.
2. Electrical conduit stub outs should be no less than 3" above grade with a minimum of 18" length of supply conductors from the end of the conduit stub outs.
3. Maximum conduit stub outs size: (2) 3/4" conduit sweeps.
4. Orient the J-bolt anchor assembly so the template bracket is flush with the final grade. The top of the J-bolts should be between 5/8" and 7/8" from the top of the template bracket. (the height of the J-bolts are pre-set at the factory).
5. The concrete pour form should be a minimum of 9" across in any direction and at least 18" deep.
6. Fill the concrete form (by others) with concrete (by others). For best results, make sure the concrete is flush with the top of the template bracket, is level, and smooth.
7. Allow the concrete to fully cure before installing the stanchion mount accessory.

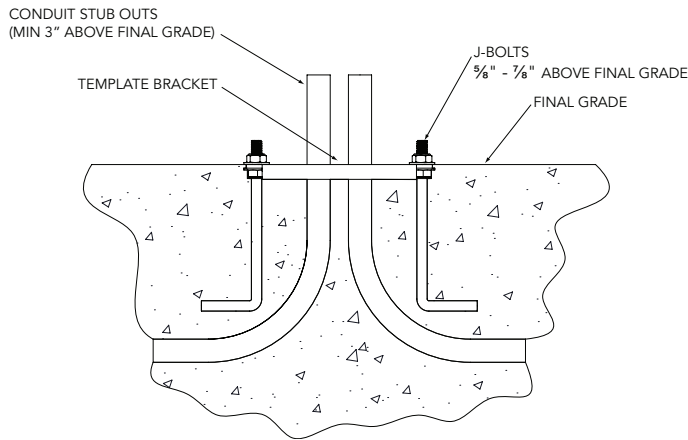
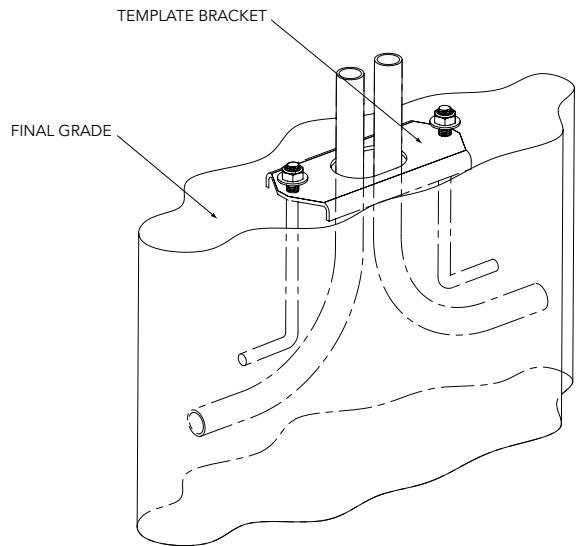

Vista Professional Outdoor Lighting reserves the right to modify the design and/or construction of the fixture shown without further notification.





STANCHION MOUNTING / INSTALLATION

1. Remove the 3/8"-16 J-bolt nuts and washers from the poured anchor assembly.
Place stanchion base over conduit stub outs, pulling the conduit wiring through the extrusion.
2. Secure the base with the 3/8"-16 nuts and washers. Securely tighten.
3. Place a pea-sized dollop of RTV silicon into the cavity of the nut cover cap. Press the nut cover caps over the J-bolt nuts until the caps are flush with the base.

FIXTURE WIRING - STANCHION INSTALLATION

1. Remove the stanchion cap from the stanchion by loosening the two 1/4-20 screws located on top of the cap. (Use a 1/8" Allen wrench provided).
2. Pull the supply conductors up through the stanchion extrusion.
3. Thread the stainless steel hinge stem (if mounting a Vista line voltage flood light) into the 1/2" NPT opening at the top of the stanchion cap. Use a suitable thread sealing method on the threads to ensure a watertight seal.

OTHER FIXTURE MOUNTINGS

1. If mounting other products, insert supply conductors through the 1/2" NPT opening. Thread the mounting stem into the 1/2" NPT opening at the top of the stanchion cap. Use a suitable thread sealing method on the threads to ensure a watertight seal.
2. Affix the fixture wiring to the supply conductors taking note of polarity. Wire black (line) conductors, white (neutral) conductors and green (ground) wiring together.
3. Tighten the stanchion cap to the extrusion with the two 1/4-20 screws provided.
4. Aim the fixture. Turn on power to check for proper function.

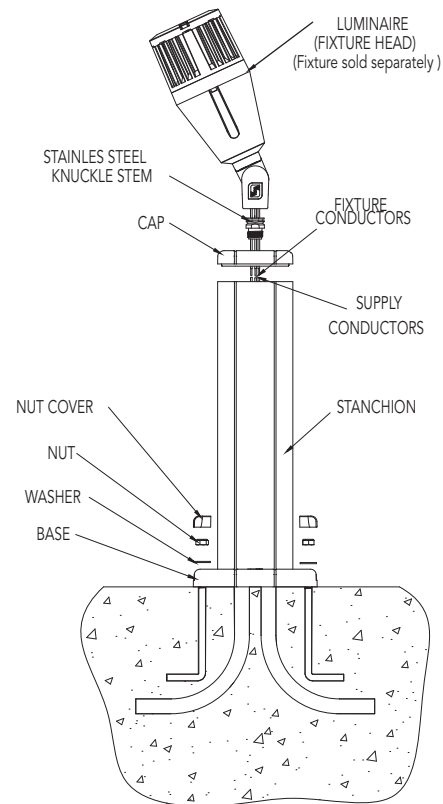

Vista Professional Outdoor Lighting reserves the right to modify the design and/or construction of the fixture shown without further notification.

