



## INSTALLATION INSTRUCTIONS

**FOR USE ONLY WITH LOW VOLTAGE LANDSCAPE POWER UNITS THAT DO NOT EXCEED 25 AMPS, 15 VOLT MAXIMUM.**

**WARNING:** Luminaires must be installed in accordance with the National Electrical Code (NEC) and local codes. Failure to do so will void the warranty and may result in serious injury and/or damage to the luminaire.

**SAFETY WARNING:** Luminaire can become very hot depending on lamp wattage used. Lens and metal around lamp can become hot enough to blister hands. Particular care should be taken not to locate luminaires where small children can reach them if high wattage lamps are used.

**LUMINAIRES ARE NOT TO BE INSTALLED WITHIN 10 FT. (3.05M) OF A POOL OR SPA. SECONDARY CABLE IS NOT TO BE BURIED MORE THAN 6". WHEN USING MULTIPLE LUMINAIRES, LOAD IS NOT TO EXCEED THE TOTAL WATTS OF TRANSFORMER RATING. DO NOT USE EXTENSION CORDS ON POWER UNITS.**

**NOTE:** Always use UL recognized wire connectors for connections.

**NOTE:** Save these instructions for future reference.

### MASONRY INSTALLATION:

1. To prevent electrical shock, disconnect transformer from electrical supply before installation or service.
2. Route luminaire pigtail wire through wiring access notch in rear cover plate (access notch allows for rear or side routing of pigtail wire).
3. Check position of weather-tight gasket on top side of fixture chassis, and adjust if necessary.
4. Mount stainless steel mounting plate to top of fixture chassis using flat-head machine screws provided.
5. Insert stainless steel mounting plate between layers of hardscape material (as an option, adhesive may be used to secure fixture position).
6. Route wire through wall to main power supply cable using standard masonry procedures.
7. Strip two leads from luminaire pigtail wire. Using two silicone filled safety connectors (provided), connect leads from luminaire to main supply cable leads.

**NOTE:** Luminaires are supplied with 60" of 18-2 cable pigtail for secure connection to main supply cable.

8. Provide power to luminaire and check for proper operation.

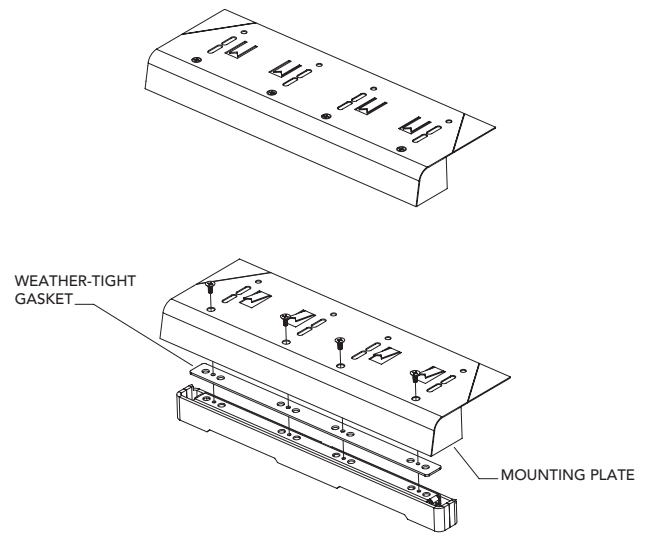

### MOUNTING PLATE MODIFICATION:

1. Using a standard circular saw with masonry compatible minimum 9" blade, cut a slot into the existing block or mortar joint.
2. Remove "snap off" corners allowing the mounting plate to conform to the standard circular saw cut.
3. Using pliers, lift tiger grips just enough to secure fixture once in position.

### MOUNTING PLATE MODIFICATION:

1. Using a standard circular saw with masonry compatible minimum 9" blade, cut a slot into the existing block or mortar joint.
2. Remove "snap off" corners allowing the mounting plate to conform to the standard circular saw cut.
3. Using pliers, lift tiger grips just enough to secure fixture once in position.

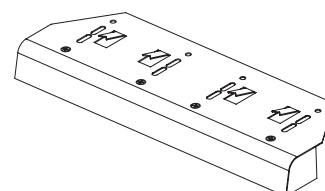
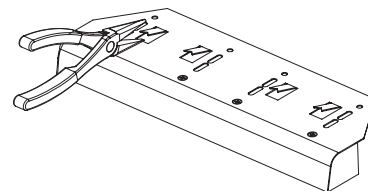
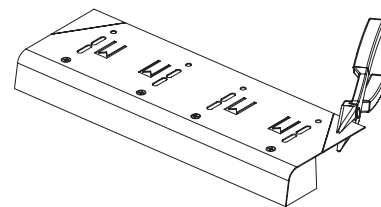

*Vista Professional Outdoor Lighting reserves the right to modify the design and/or construction of the fixture shown without further notification.*



## LAMP INSTALLATION/REPLACEMENT

### IMPORTANT SAFETY INSTRUCTIONS - THE LIGHTED LAMP IS HOT!

**WARNING: TO REDUCE THE RISK OF FIRE, OR INJURY TO PERSONS:**

- |                                                                                                                                                                                                                                                   |                                                                                                                                                                                                                                                                                    |
|---------------------------------------------------------------------------------------------------------------------------------------------------------------------------------------------------------------------------------------------------|------------------------------------------------------------------------------------------------------------------------------------------------------------------------------------------------------------------------------------------------------------------------------------|
| <ol style="list-style-type: none"> <li>1. Turn off/unplug and allow to cool before replacing lamp.</li> <li>2. Lamps get hot quickly! Contact only switch/plug when turning on.</li> <li>3. Do not touch hot lens, guard or enclosure.</li> </ol> | <ol style="list-style-type: none"> <li>4. Keep lamp away from material that may burn.</li> <li>5. Do not touch the lamp at any time. Use a soft cloth. Oil from the skin may damage lamp.</li> <li>6. Do not operate luminaire fitting with a missing or damaged cover.</li> </ol> |
|---------------------------------------------------------------------------------------------------------------------------------------------------------------------------------------------------------------------------------------------------|------------------------------------------------------------------------------------------------------------------------------------------------------------------------------------------------------------------------------------------------------------------------------------|

SAVE THESE INSTRUCTIONS (Leave with property owner/manager)

### LAMP INSTALLATION/REPLACEMENT:

**CAUTION:** Do not exceed maximum wattage marked on luminaire label.

1. To prevent electrical shock, disconnect transformer from electrical supply before service.
2. Pull back lens retaining clip just far enough to remove lens.
3. Tilt down lamp bracket.
4. Replace lamps with correct wattage and type marked on fixture label.
5. Push lamp bracket back into position.
6. Replace lens.

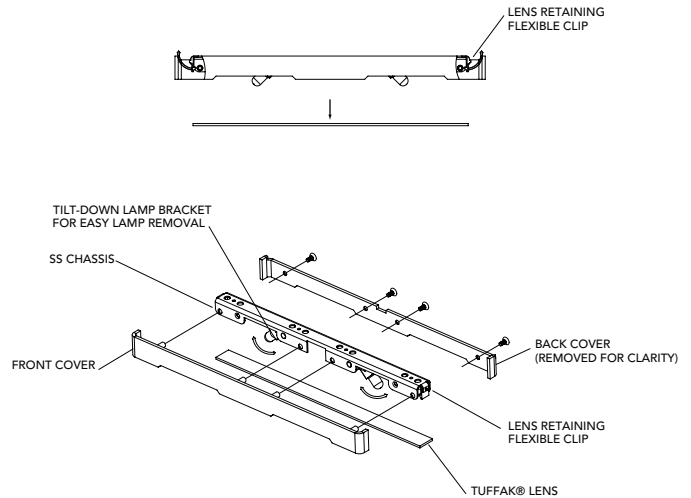

### LED ENGINE INSTALLATION/REPLACEMENT:

1. To prevent electrical shock, disconnect transformer from electrical supply before service.
2. If tamper-proof clips are locked, loosen screws and slide clips open. The fixture is shipped from factory with tamper-proof clips in locked position. Release clips prior to installation/replacement if desired.

3. Detach LED engine from magnet in chassis by pulling tabs (Fig. 1).
4. Observing correct alignment & orientation, snap new LED engine magnetically back in to the chassis (Fig. 2).

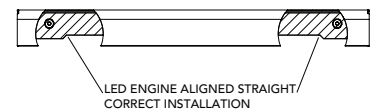
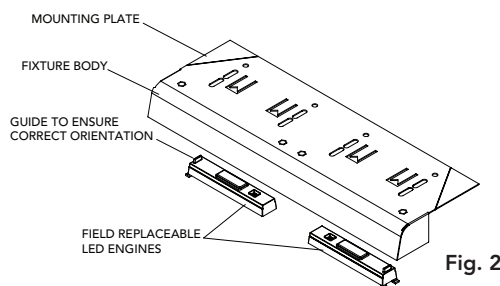
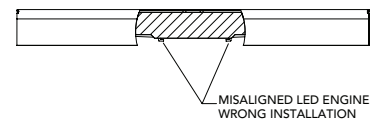
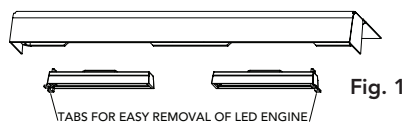
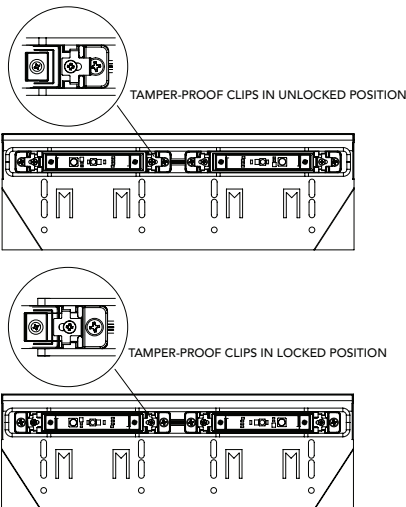

The operating voltage range for this LED luminaire is 6 - 15 volt AC. The Vista electronic driver ensures the LED operates at the intended lumen output while receiving voltage as low as 6 volts, and as high as 15 VAC, resulting in a balanced lumen output from the first fixture to the last. Eliminating the dimness issues often attributed to voltage drop.

Note: Operating voltage range for LED luminaries will vary depending on model, style and total number of LEDs. To help determine the operating voltage range for each Vista luminaire, always consult factory's specification sheet and/or installation instructions before installation.

Vista Professional Outdoor Lighting reserves the right to modify the design and/or construction of the fixture shown without further notification.