

INSTALLATION INSTRUCTIONS

FOR USE ONLY WITH LOW VOLTAGE LANDSCAPE POWER UNITS THAT DO NOT EXCEED 25 AMPS, 15 VOLT MAXIMUM.

WARNING: Luminaires must be installed in accordance with the National Electrical Code (NEC) and local codes. Failure to do so will void the warranty and may result in serious injury and/or damage to the luminaire.

SAFETY WARNING: Luminaire can become very hot depending on lamp wattage used. Lens and metal around lamp can become hot enough to blister hands. Particular care should be taken not to locate luminaires where small children can reach them if high wattage lamps are used.

LUMINAIRES ARE NOT TO BE INSTALLED WITHIN 10 FT. (3.05M) OF A POOL OR SPA. SECONDARY CABLE IS NOT TO BE BURIED MORE THAN 6". WHEN USING MULTIPLE LUMINAIRES, LOAD IS NOT TO EXCEED THE TOTAL WATTS OF TRANSFORMER RATING. DO NOT USE EXTENSION CORDS ON POWER UNITS.

NOTE: Always use UL recognized wire connectors for connections.

NOTE: Save these instructions for future reference.

LUMINAIRE IS UL LISTED FOR ABOVE GROUND INSTALLATION ONLY.



LUMINAIRE MOUNTING:

1. To prevent electrical shock, disconnect transformer from electrical supply before installation or service.
 2. Using wiring compartment (J-box) as a template, mark mounting hole positions.
 3. Use appropriate anchoring screws (by others) to mount J-box to mounting surface.
 4. Strip two (2) leads from luminaire pigtail. Using two (2) safety connectors (provided), connect leads from luminaire to main supply cable leads.
- NOTE:** Luminaires are supplied with 60" of 18-2 cable pigtail for secure connection to main supply cable.
5. Provide power to luminaire and check for proper operation.
- NOTE:** Avoid aiming fixture directly upward. Whenever possible, set at angle to prevent rain or irrigation water from settling on lens.

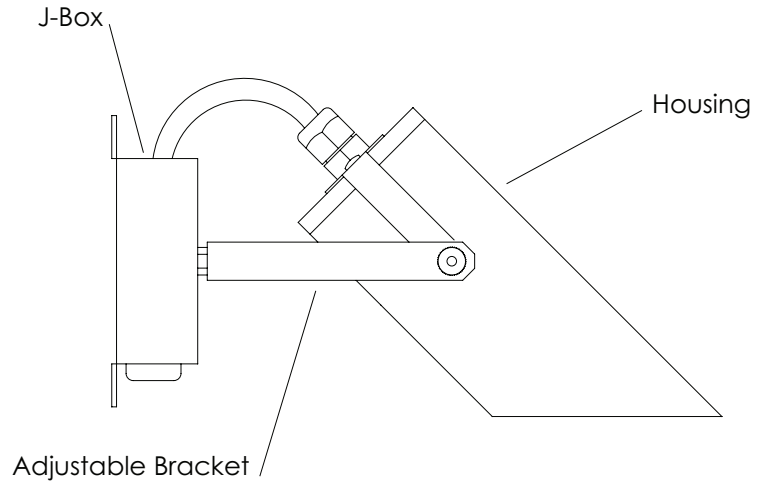

IMPORTANT SAFETY INSTRUCTIONS - THE LIGHTED LAMP IS HOT!

WARNING: TO REDUCE THE RISK OF FIRE, OR INJURY TO PERSONS:

1. Turn off/unplug and allow to cool before replacing lamp.
2. Lamps get hot quickly! Contact only switch/plug when turning on.
3. Do not touch hot lens, guard or enclosure.

4. Keep lamp away from material that may burn.
5. Do not touch the lamp at any time. Use a soft cloth. Oil from the skin may damage lamp.
6. Do not operate luminaire fitting with a missing or damaged cover.

SAVE THESE INSTRUCTIONS
(Leave with property owner/manager)

LAMP INSTALLATION/REPLACEMENT:

CAUTION: Do not exceed maximum wattage marked on luminaire label.

1. To prevent electrical shock, disconnect transformer from electrical supply before service.
2. Loosen screw from shroud.
3. Remove shroud to expose lamp.
4. Replace lamp with correct wattage and type marked on fixture label.

NOTE: DO NOT touch lamp with bare hands. Always use soft cloth to handle lamp.

5. Re-install shroud and tighten shroud screw.

NOTE: Halogen lamps must be protected from moisture and dust at all times. Always re-install shroud and lens when removed.

INSTALLATION INSTRUCTIONS

FOR USE ONLY WITH LOW VOLTAGE LANDSCAPE POWER UNITS THAT DO NOT EXCEED 25 AMPS, 15 VOLT MAXIMUM.

WARNING: Luminaires must be installed in accordance with the National Electrical Code (NEC) and local codes. Failure to do so will void the warranty and may result in serious injury and/or damage to the luminaire.

SAFETY WARNING: Luminaire can become very hot depending on lamp wattage used. Lens and metal around lamp can become hot enough to blister hands. Particular care should be taken not to locate luminaires where small children can reach them if high wattage lamps are used.

LUMINAIRES ARE NOT TO BE INSTALLED WITHIN 10 FT (3.05M) OF A POOL OR SPA. SECONDARY CABLE IS NOT TO BE BURIED MORE THAN 6". WHEN USING MULTIPLE LUMINAIRES, LOAD IS NOT TO EXCEED TOTAL WATTS OF TRANSFORMER RATING. DO NOT USE EXTENSION CORDS ON POWER UNITS.

NOTE: Always use UL recognized wire connectors for connections.

NOTE: Save these instructions for future reference; leave with property owner/manager.

LUMINAIRE MOUNTING:

1. To prevent electrical shock, disconnect transformer from electrical supply before installation or service.
2. Using wiring compartment (J-box) as a template, mark mounting hole positions.
3. Use appropriate anchoring screws (by others) to mount J-box to mounting surface.
4. Strip two (2) leads from luminaire pigtail. Using two (2) safety connectors (provided), connect leads from luminaire to main supply cable leads.

NOTE: Luminaires are supplied with 60" of 18-2 cable pigtail for secure connection to main supply cable.

5. Provide power to luminaire and check for proper operation.

NOTE: Avoid aiming fixture directly upward. Whenever possible, set at angle to prevent rain or irrigation water from settling on lens.

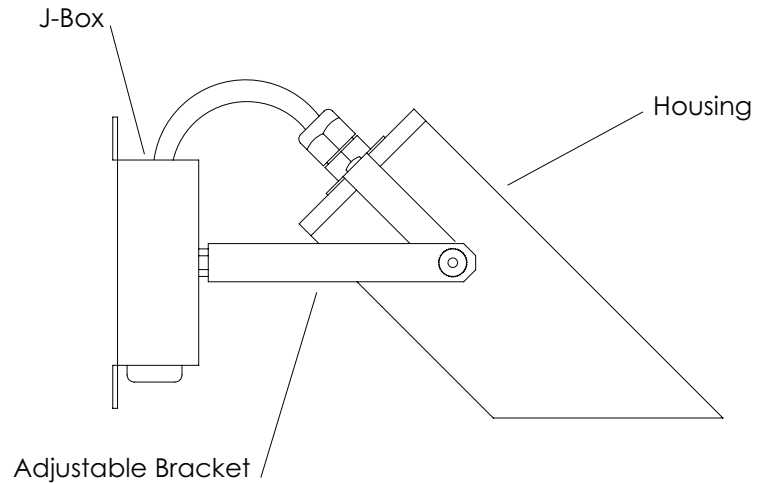

The operating voltage range for this LED luminaire is 6 - 15 volt AC. The Vista electronic driver ensures the LED operates at the intended lumen output while receiving voltage as low as 6 volts, and as high as 15 VAC, resulting in a balanced lumen output from the first fixture to the last. Eliminating the dimness issues often attributed to voltage drop.

Note: Operating voltage range for LED luminaires will vary depending on model, style and total number of LEDs. To help determine the operating voltage range for each Vista luminaire, always consult factory's specification sheet and/or installation instructions before installation.

LED ENGINE INSTALLATION/REPLACEMENT:

1. To prevent electrical shock, disconnect transformer from electrical supply before service.
2. Loosen shroud locking screw.
3. Remove shroud to expose field replaceable LED engine.
4. Remove stainless steel locking/expansion ring.
5. Pull up LED engine assembly out of fixture body.
6. Disconnect Connector Assembly.
7. Connect new Field Replaceable LED Engine to Connector Assembly.
8. Re-install LED base assembly onto fixture body.
9. Re-install stainless steel locking/expansion ring.
10. Re-install shroud and locking screw.

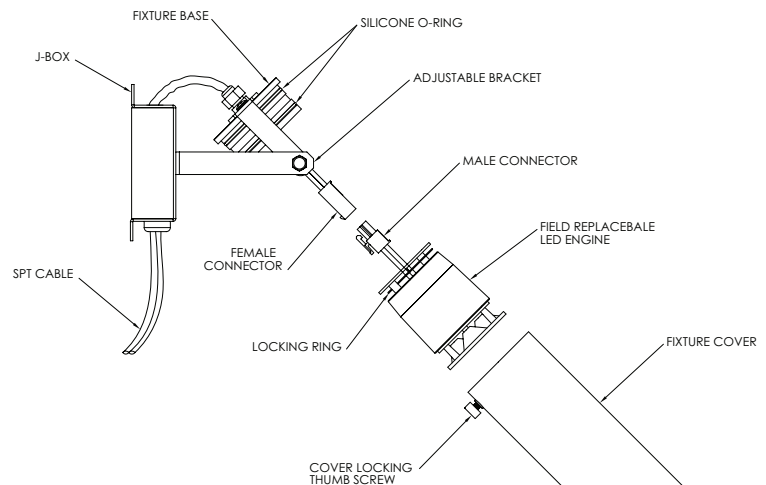

Vista Professional Outdoor Lighting reserves the right to modify the design and/or construction of the fixture shown without further notification.